

# 125T-15 C ( europell、E-mark、 front/rear disc、 case lengthen ) PARTS LIST



图1 曲轴箱总成

FIG.1 CRANKCASE COMP

型号	序号	图号	零部件编码	英文名称
TOTAL NO	NO		PQRT NO	ENGLISH NAME
HS1P52QM	1	11100-F22B-0000	T1101	CRANKCASE ASSY L
HS1P52QM	2	11102-F21-0000	T1102	BUSH ENGINE HABGER RUBBERΦ28
HS1P52QM	3	91212-F21-0000	T1103	GASKET CRAKCASE
HS1P52QM	4	11103-F21-0000	T1201	BUSH RR CUSHION UNDER RUBBERΦ20
HS1P52QM	5	91101-F21-0000	T1205	OIL SEAL Φ19.8*30*5
HS1P52QM	6	91102-F21-0000	T1206	OIL SEAL Φ27*42*7
HS1P52QM	7	16674-6002	T1207	BEARING RADLAL BALL 6002
HS1P52QM	8	6177.2-6004	T1208	BEARING RADLAL BALL 6004
HS1P52QM	9	276-6301	T1209	BEARING RADLAL BALL 6301
HS1P52QM	10	11200-F21-0000	T1221	CRANKCASE ASSY R
HS1P52QM	11	18602-F21-0000	T1228	TUBE BREATHER
HS1P52QM	12	90031-F21-0000	125-T0010-011	BOLT STUP 8*187.5
HS1P52QM	13	90032-F21-0000	125-T0010-011	BOLT STUP 8*195.5
HS1P52QM	14	90801-F21-0000	125-T0010-016	PIN DOWEL Φ8*14
HS1P52QM	15	5787-6-50	GB/T5787-86	BOLT FLANGE 6*50
HS1P52QM	16	6187-8-00	GB/T6187-2000	NUT FLANCE M8
HS1P52QM	17	96-12-00	GB/T96-85	WASHER DRAIN PLUG Φ12MM
HS1P52QM	18	15.12.5790	125-T0010-012	BOLT DRAIN PLUG M12
HS1P52QM	19	97.1-12-00	GB/T97.1-85	WASHER DRAIN PLUG Φ12MM
HS1P52QM	20	14300-F21-0000	T1318	CHAIN CAM
HS1P52QM	21	14520-F21-0000	T1326	TENSIONER CAM CHAIN
HS1P52QM	22	14630-F21-0000	T1327	GUIDE COMP CAM CHAIN
HS1P52QM	23	14500-F21-0000	T1328	LIFTER ASSY TENSIONER
HS1P52QM	24	91205-F21-0000	T1329	O-RING Φ9.5*1.5
HS1P52QM	25	14521-F21-0000	T1331	PIVOT CAM CHAIN TENSIONER
HS1P52QM	26	91206-F21-0000	T1339	O-RING Φ15*1.5
HS1P52QM	27	91218-F21-0000	T1341	GASKET TENSIONER LIFTER
HS1P52QM	28	22.06.5787	GB/T5787-86	IBOLT FLANGE M6*22
HS1P52QM	29	818-6-6	GB/T818-88	CSCREW PAN M6*6

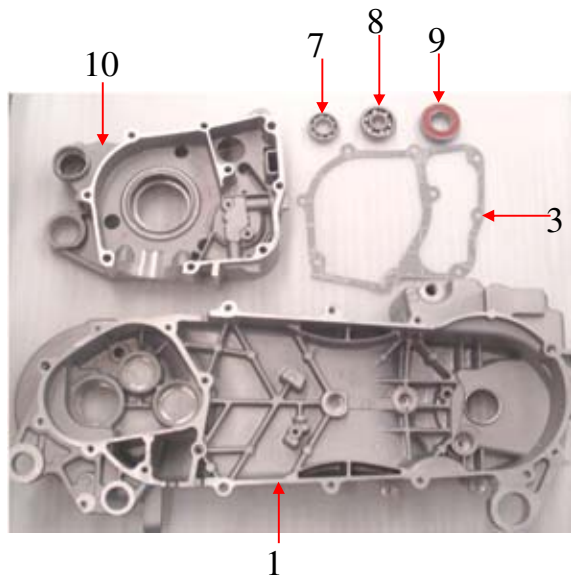

图2 变速箱盖总成

FIG.2 GEAR-BOX COVER ASSY.

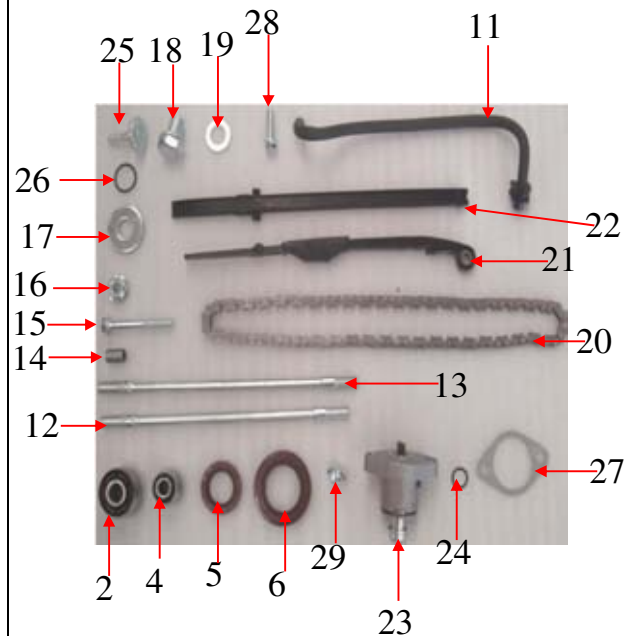
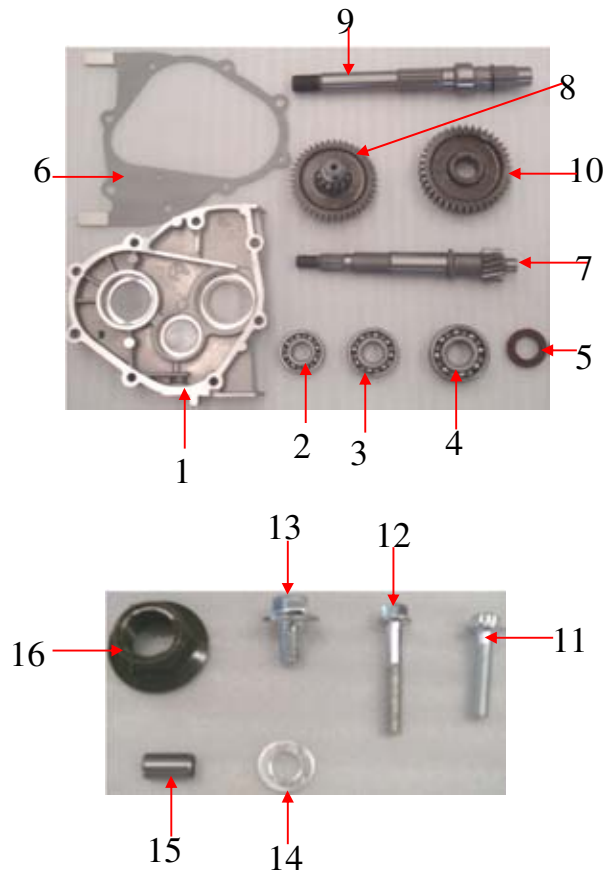

型号	序号	图号	零部件编码	英文名称
TOTAL NO	NO		PQRT NO	ENGLISH NAME
HS1P52QM	1	22700-F21-0000	T1701	COVER MISSION ASSY
HS1P52QM	2	276-6202	T1702	BEARING RADLAL BALL 6202
HS1P52QM	3	276-6203	T1703	BEARING RADLAL BALL 6203
HS1P52QM	4	276-6204	T1704	BEARING RADLAL BALL 6204
HS1P52QM	5	91103-F21-0000	T1706	OIL SEAL $\Phi 20 \times 32 \times 6$
HS1P52QM	6	91221-F21-0000	91211-F21-0000	GASKET MISSON COVER
HS1P52QM	7	22701-F21-0000	T2001	SHAFT DRIVE
HS1P52QM	8	22702-F21-0000	T2002	SHAFT COMP COUNTER
HS1P52QM	9	22703-F21-0000	T2003	SHAF FINAL
HS1P52QM	10	22704-F21-0000	T2004	GEAR FINAL
HS1P52QM	11	28.06.5787	GB/T5787-86	BOLT FLANGE 6*28
HS1P52QM	12	5787-6-35	GB/T5787-86	BOLT FLANGE 6*35
HS1P52QM	13	12.08.5787	GB/T5787-86	BOLT SPECLAL M8*20
HS1P52QM	14	97.1-5-00	GB/T97.1-85	WASHER $\Phi 8 \text{MM}$
HS1P52QM	15	90801-F21-0000	125-T0010-016	PIN DOWEL $\Phi 8 \times 14$
HS1P52QM	16	6187-16-00	GB/T6187-2000	NUT M16

图3 左盖总成

FIG.3 L. COVER COMP.



型号	序号	图号	零部件编码	英文名称
TOTAL NO	NO		PQRT NO	ENGLISH NAME
HS1P52QM	1	11300-F22B-0000	T1222	COVER L
HS1P52QM	2	11301-F21-0000	T1223	PLATE L COVER
HS1P52QM	3	91501-F21-0000	T1224	CLAMPER BRAKE CABLE
HS1P52QM	4	91502-F21-0000	T1225	CLAMPER BRATHER DRAIN TUBE
HS1P52QM	5	91214-F22B-0000	T1227	GASKET L COVER
HS1P52QM	6	91504-F21-0000	T1229	CLAMPER THROTTLE CABLE
HS1P52QM	7	90801-F21-0000	125-T0010-016	PIN DOWEL $\Phi 8 \times 14$



HS1P52QM	8	845-3.8-8	GB/T845-85	SCREW TAPPINGST3.8*8
HS1P52QM	9	5787-6-40	GB/T5787-86	BOL FLANGE 6*40
HS1P52QM	10	5787-6-45	GB/T5787-86	BOL FLANGE 6*45
HS1P52QM	11	91511-F21-0000	T2122	BLOCK, MAIN STAND
HS1P52QM	12	5787-6-65	GB/T5787-86	BOL FLANGE 6*65
HS1P52QM	13	21900-F21-0000	T2033	LEVER.ASSY.KICK STARTER

图4 右箱体端盖总成

FIG.4 RIGHT CRANKCASE COVER COMP.

型号	序号	图号	零部件编码	英文名称
TOTAL NO	NO		PQRT NO	ENGLISH NAME
HS1P52QM	1	91101-F21-0000	T1205	OIL SEAL 19.8*30*5
HS1P52QM	2	11400-F21-0000	T1213	COVER R CRANKCASE COMP
HS1P52QM	3	91202-F21-0000	T1214	O-RING Φ18*3
HS1P52QM	4	15214-F21-0000	T1215	GAUGE OIL LEVEL
HS1P52QM	5	15212-F21-0000	T1216	CAP TAPPET ADJUSTING HOLE
HS1P52QM	6	15211-F21-0000	T1217	SCREEN OIL FILTER SCREEN
HS1P52QM	7	15213-F21-0000	T1218	SPRING OIL FILTER SCREEN
HS1P52QM	8	91203-F21-0000	T1219	O-RING Φ30.8*3mm
HS1P52QM	9	91213-F21-0000	T1226	GASKET R CRANKCAE COVER
HS1P52QM	10	91510-F21-0000	T2114	CLAMPER A.C.GENERATOR CORD
HS1P52QM	11	90801-F21-0000	125-T0010-016	PIN DOWEL Φ8*14
HS1P52QM	12	28.06.5787	GB/T5787-86	BOLT FLANGE M6*28
HS1P52QM	13	5787-6-95	GB/T5787-86	BOLT FLANGEM6*95
HS1P52QM	14	5787-6-100	GB/T5787-86	BOLT FLANGEM6*100
HS1P52QM	15	5787-6-110	GB/T5787-86	BOLT FLANGE M6*110
HS1P52QM	16	5787-6-35	GB/T5787-86	BOLT FLANGE M6*35

图5 气缸体总成

FIG.5 CYLINDER COMP.



型号	序号	图号	零部件编码	英文名称
TOTAL NO	NO		PQRT NO	ENGLISH NAME
HS1P52QM	1	12100-F21-0000	1P52QMI-1301	CYLINDER COMP
HS1P52QM	2	91215-F21-0000	1P52QMI-1302	CASKET CYLINDER

1 2

HS1P52QM	3	90802-F21-0000	125-T0010-016	PIN DOWEL $\Phi 10 \times 16$

图6 气缸头总成

FIG.6 CYLINDER HEAD ASSY.

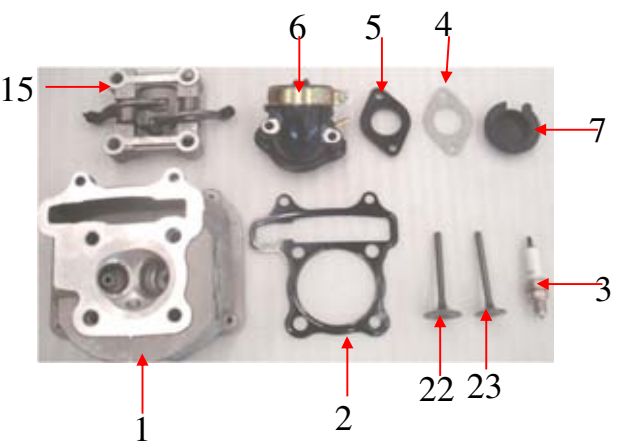

型号	序号	图号	零部件编码	英文名称
TOTAL NO	NO		PQRT NO	ENGLISH NAME
HS1P52QM	1	12200-F21-0000	1P52QMI-1303	HEAD COPM CYLINDER
HS1P52QM	2	91216-F21-0000	1P52QMI-1304	GASKET CYLINDER HEAD
HS1P52QM	3	33300-F21-0000	T1304	PLUG SPARK ( A7RTC NGK )
HS1P52QM	4	91219-F21-0000	T1501	COVER
HS1P52QM	5	91220-F21-0000	T1502	INSULATOR , IN PIPE
HS1P52QM	6	14800-F21-0000	T1503	INSULATOR COPM , CARBURETOP
HS1P52QM	7	14801-F21-0000	T1504	DUSTPROOF COVER, INLET PIPE
HS1P52QM	8	899-6-32	125-T0010-011	BOLT , SPECLAL STUD , 6*32
HS1P52QM	9	899-6-63	125-T0010-011	BOLT , SPECLAL STUD , 6*63
HS1P52QM	10	6177.1-6-00	GB/T6177.1-86	NUT FLANGE 6mm
HS1P52QM	11	6177.1-8-00	GB/T6177-.186	NUT FLANGE 8mm
HS1P52QM	12	90802-F21-0000	125-T0010-016	PIN DOWEL $\Phi 10 \times 16$
HS1P52QM	13	5787-6-100	GB/T5787-86	BOLT FLANGE 6*100
HS1P52QM	14	91104-F21-0000	T1305	SEAL VALVE STME $\Phi 27 \times 25 \times 10.6 \times 6.7 \times 8.4$
HS1P52QM	15	12250-F21-0000	T1310	BRACKET,SEAT FIXUP
HS1P52QM	16	13120-F21-0000	T1317	CAMSHAFT COMP
HS1P52QM	17	14751-F21-0000	T1334	SPRING VALVE OUTER
HS1P52QM	18	14761-F21-0000	T1335	SPRING VALVE INTER
HS1P52QM	19	14771-F21-0000	T1336	RETAINER VALVE SPRING
HS1P52QM	20	14775-F21-0000	T1337	SEAT VALVE SPRING OUTER
HS1P52QM	21	14781-F21-0000	T1338	COTTER VALVE
HS1P52QM	22	14711-F21-0000	1P52QMI-1332	VALVE IN
HS1P52QM	23	14721-F21-0000	1P52QMI-1333	VALVE EX

图7 气缸头盖总成

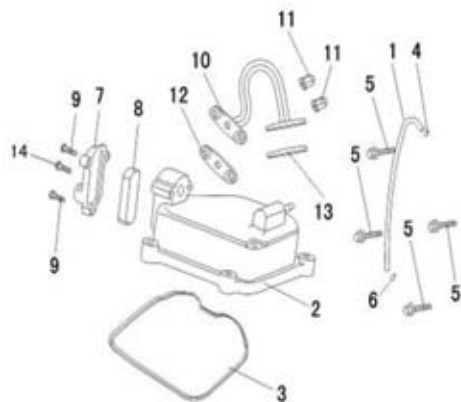

FIG.7 CYLINDER HEAD COVER COMP

型号	序号	图号	零部件编码	英文名称
TOTAL NO	NO		PQRT NO	ENGLISH NAME
HS1P52QM	1	18601-F21-0000	T1211	
HS1P52QM	2	12310-F21-0000	T1311	
HS1P52QM	3	12391-F21-0000	T1314	
HS1P52QM	4	91504-F21-0000	T1312	
HS1P52QM	5	16674-6-25	GB5787-86	
HS1P52QM	6	91505-F21-0000	T1313	
HS1P52QM	7	12311-F21-0000	T1320	
HS1P52QM	8	12312-F21-0000	T1321	
HS1P52QM	9	16674-6-32	GB5787-86	
HS1P52QM	10	12313-F21-0000	T1309	
HS1P52QM	11	12314-F21-0000	T0010-002	
HS1P52QM	12	12315-F21-0000	T1307	
HS1P52QM	13	12316-F21-0000	T1308	
HS1P52QM	14	16674-6-25	GB5787-86	

图8 曲轴连杆组件、活塞组件

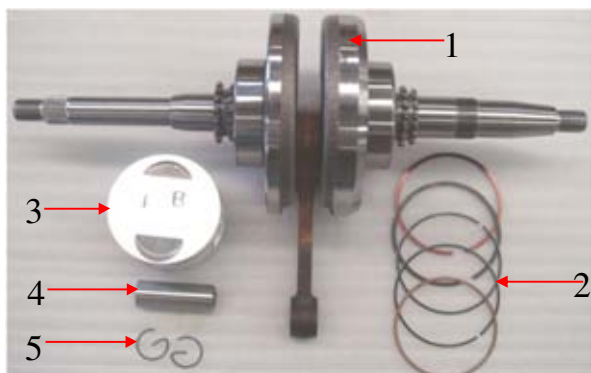

FIG.8 CRANKCASE SHAFT、PISTON COMP

型号	序号	图号	零部件编码	英文名称
TOTAL NO	NO		PQRT NO	ENGLISH NAME
HS1P52QM	1	13200-F21-0000	T1319	CRANKSHAFT COMP
HS1P52QM	2	13120-F21-0000	1P52QMI-1321	RING SET PISTON ( STD )
HS1P52QM	3	13100-F21-0000	1P52QMI-1322	RISTON ( STD )
HS1P52QM	4	13111-F21-0000	1P52QMI-1323	PIN PISTON
HS1P52QM	5	91301-F21-0000	T1325	CLIP PISTON PIN Φ15MM

图9 电起动部件



FIG.9 ELECTRIC STARTING ASSY

型号	序号	图号	零部件编码	英文名称
TOTAL NO	NO		PQRT NO	ENGLISH NAME
HS1P52QM	1	24401-F21-0000	T2101	GEAR STARTER REDUCTION

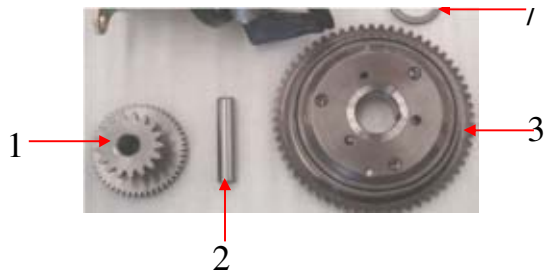

HS1P52QM	2	24402-F21-0000	T2102	SHAFI STARTER REDUCTION GEAR
HS1P52QM	3	24300-F21-0000	1P52QMI-2010	OUTER COMP STARTING CLUTCH
HS1P52QM	4	31200-F21-0000	T2111	MOTOR ASSY STARER
HS1P52QM	5	16.06.5787	GB/T5787-86	BOLT RLANGE 6*16
HS1P52QM	6	31202-F21-0000	125-T0010-013	NUT LOCK 22MM
HS1P52QM	7	96-22-00	GB/T96-85	WASHER THRUST $\Phi$ 22.2*31*2.5



图10 驱动轮总成				
FIG.10 DRIVE GEAR ASSY				
型号	序号	图号	零部件编码	英文名称
TOTAL NO	NO		PQRT NO	ENGLISH NAME
HS1P52QM	1	21390-F21-0000	T1203	BAFFLE STARTER LEVER SPRING
HS1P52QM	2	21607-F21-0000	T2011	GEAR KICK DRIVEN ( 20T )
HS1P52QM	3	21600-F21-0000	T1810	DRIVE GEAR ASSY
HS1P52QM	4	21700-F21-0000	T2020	GEAR COMP STARTER IDLE ( 13T/49T )
HS1P52QM	5	21800-F21-0000	T2030	SPINDLE COMP KICK STARTER
HS1P52QM	6	14.06.5787	GB/T5787-86	BOLT FLABGE M6*14
HS1P52QM	7	97.1-12-00	GB/T97.1-85	WASHER PLWIN $\Phi$ 12MM
HS1P52QM	8	6177.1-12-00	GB/T6177.1-2000	NUT FLANGE M12



图11 从动轮皮带总成				
FIG.11 FACE ASSY DRIVEN				
型号	序号	图号	零部件编码	英文名称
TOTAL NO	NO		PQRT NO	ENGLISH NAME
HS1P52QM	1	21202-F22B-0000	T1901	BELT DRIVE
HS1P52QM	2	21100-F21-0000	T1910	FACE ASSY DRIVEN
HS1P52QM	3	6177.1-12-00	GB/T6177.1-2000	NUT COMPRESSOR FLANGE 12MM
HS1P52QM	4	97.1-12-00	GB/T97.1-85	WASHER PLAIN $\Phi$ 12MM

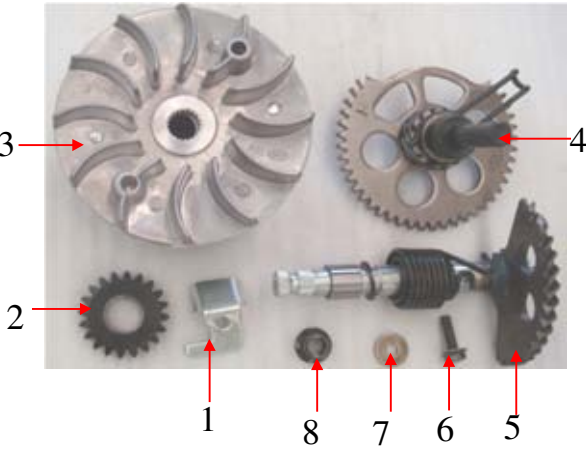

图12 磁电机总成				
-----------	--	--	--	--

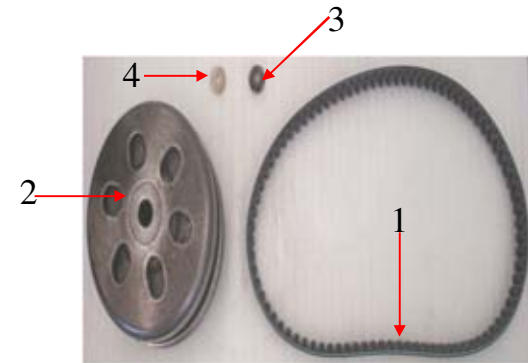
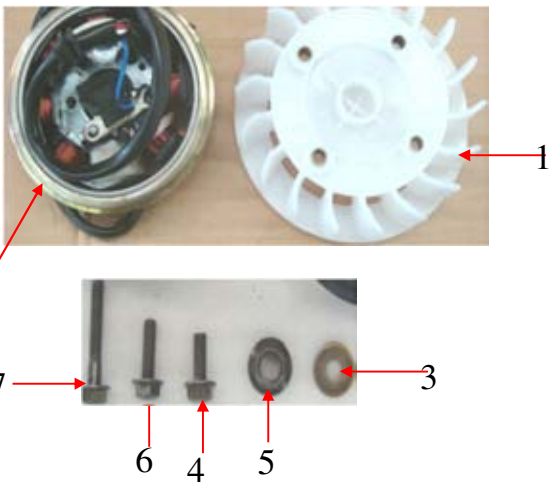

FIG.12 MAGNETO ASSY				
型号	序号	图号	零部件编码	英文名称
TOTAL NO	NO		PQRT NO	ENGLISH NAME
HS1P52QM	1	19110-F21-0000	T1601	PAN COMP COOLING
HS1P52QM	2	31100-F21-0000	T2110	CENERATOR ASSY FLYWHEEL A.C
HS1P52QM	3	97.1-12-00	GB/T97.1-85	WASHER PLANI Φ12MM
HS1P52QM	4	12.05.2021	GB/T21-1976	BOLT HEX M5*12
HS1P52QM	5	6177.1-12-00	GB/T6177.1-2000	NUT FLANGE M12
HS1P52QM	6	57587-6-18	GB/T5787-86	BOLT FLANGE M6*18
HS1P52QM	7	25.06.5787	GB/T5787-86	BOLT FLANGE M6*25

图13 导风罩

FIG.13 SHROUD COMP



图13 导风罩				
FIG.13 SHROUD COMP				
型号	序号	图号	零部件编码	英文名称
TOTAL NO	NO		PQRT NO	ENGLISH NAME
HS1P52QM	1	19101-F21A-0000	T1602	COVER COMP FAN
HS1P52QM	2	19103-F21A-0000	T1603	SHROUD A
HS1P52QM	3	19106-F21A-0000	T1604	SHROUD COMP B
HS1P52QM	4	19102-F21A-0000	T1605	CUCT CARBUETTOR COOLING
HS1P52QM	5	91508-F21A-0000	T1606	CLIP HIGH TENSION CORD
HS1P52QM	6	19108-F21A-0000	T1607	CROMMET B SIDE PANEL
HS1P52QM	7	91509-F21A-0000	T2113	CLAMPERS STARTER CABLE
HS1P52QM	8	21-5-12	GB/T21-1976	SCREW TAPPING 5*12
HS1P52QM	9	845-5-16	GB/T845-85	SCREW TAPPING 5*16
HS1P52QM	10	25.06.5787	GB/T5787-86	BOLT FLANGE 6*25

图14 机油泵组合

FIG.14 OIL PUMP ASSY.

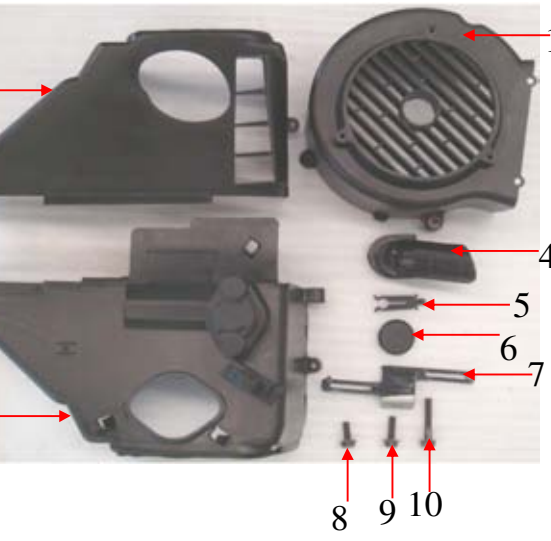

图14 机油泵组合				
FIG.14 OIL PUMP ASSY.				
型号	序号	图号	零部件编码	英文名称
TOTAL NO	NO		PQRT NO	ENGLISH NAME
HS1P52QM	1	15100-F21-0000	T1410	PUMP ASSY OIL
HS1P52QM	2	15003-F21-0000	T1411	SPROKET OIL PUMP



HS1P52QM	3	15002-F21-0000	T1412	CHAIN OIL PUMP
HS1P52QM	4	15001-F21-0000	T1413	SEPARATOR OIL
HS1P52QM	5	6177.1-6-00	GB/T6177.1-86	BOLT FLANGE, 6
HS1P52QM	6	25.06.5787	GB/T5787-86	BOLT FLANGE, 6*25
HS1P52QM	7	12.06.5787	GB/T5787-86	BOLT FLANGE, 6*12

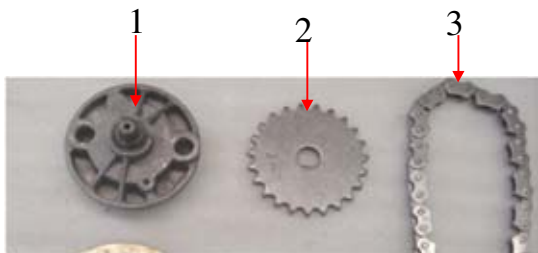
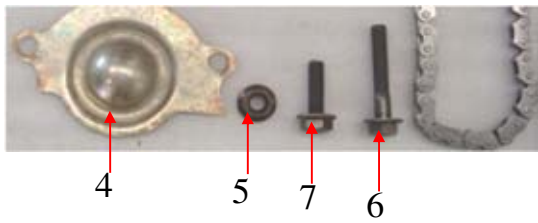

图15 化油器

FIG.16 CARBURETOR

型号	序号	图号	零部件编码	英文名称
TOTAL NO	NO		PQRT NO	ENGLISH NAME
HS125T-15	1	16100-145-0200	125T-T0040	CARBURETOR

1

图17 方向把总成

STEERING HANDLE ASSY

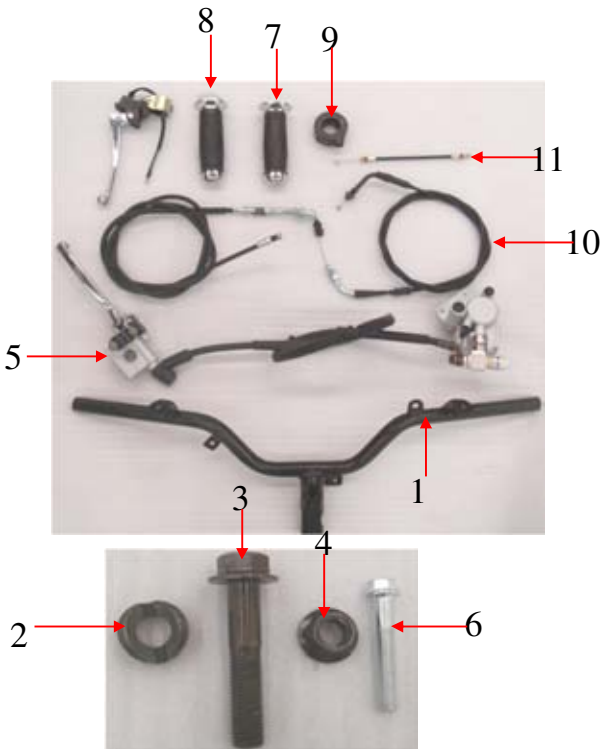

型号	序号	图号	零部件编码	英文名称
TOTAL NO	NO		PQRT NO	ENGLISH NAME
HS150T-2	1	61101-145D-0000	150T2A-15009 4D	STEERING HANDLE BAR
HS150T-2	2	90208-145D-0000	125-T0010-008	DISTANCE SLEEVE
HS150T-2	3	5787-10-45	GB/T5787-86	BOLT M10*45
HS150T-2	4	6187-10-00	GB/T6187-2000	NUT M10
HS150T-2	5	44100-145-0100	125T15-34010	FR, HYDRAULIC BRAKE ASSY
HS150T-2	6	25.08.5787	GB/T5787-86	BOLT M8*25
HS150T-2	7	43700-145-0000	125T15-27005	HANDLE BAR L
HS150T-2	8	43800-145-0000	125T15-27006	THROTTLE GRIP
HS150T-2	9	61730-145-0000	125T15-27007	FIXING SEAT GAS
HS150T-2	10	61500-145-0000	125T15-28001	CABLE THROTTLE
HS150T-2	11	71130-145-0000	125T15-28002	CABLE CUSHION



图18 前后减震器总成

## FR&amp;RR SUSPENION ASSY

型号	序号	图号	零部件编码	英文名称
TOTAL NO	NO		PQRT NO	ENGLISH NAME
HS150T-2	1	62121-145-0000	125T15-15011	STEERING STEM ASSY
HS150T-2	2	55310-145-0000	125T15-19010	FR. L SHOCK ABSORBER
HS150T-2	3	55340-145-0000	125T15-19020	FR. R SHOCK ABSORBER
HS150T-2	4	55510-145-0000	125T15-19021	REAR SHOCK ABSORBER
HS150T-2	5	62122-145-0000	125T15-16001	INNER RING BEARING UP
HS150T-2	6	62123-145-0000	125T15-16002	EX RING BEARING BEARING UP
HS150T-2	7	62124-145-0000	125T15-16003	STEEL BALL BREATHER
HS150T-2	8	62125-145-0000	125T15-16004	WASHER
HS150T-2	9	62126-145-0000	125T15-16005	Linder cover bearing race
HS150T-2	10	62127-145-0000	125T15-16006	NUT LOCKING 1
HS150T-2	11	62128-145-0000	125T15-16007	NUT LOCKING 2
HS150T-2	12	44101-145-0000	125T15-19022	CLIP
HS150T-2	13	16.06.5787	GB/T5787-86	BOLT M6*16
HS150T-2	14	5787-10-45	GB/T5787-86	BOLT M10*45
HS150T-2	15	5783-8-35	GB/T5783-2000	BOLT M8*35
HS150T-2	16	5787-8-40	GB/T5787-86	BOLT M8*40
HS150T-2	17	44501-145-0000	125T15-19023	CLIP

图19 前后轮总成

## FR&amp;RR WHEEL ASSY

型号	序号	图号	零部件编码	英文名称
TOTAL NO	NO		PQRT NO	ENGLISH NAME
HS150T-2	1	41160-145-0100	125T15-18001	FRONT RR. TYPE130/60-13
HS150T-2	2	41120-145-0000	125T15-18002	VALVE
HS150T-2	3	36330-145-0000	125T15-28003	MILEOMTERCABLE
HS150T-2	4	41110-145-0100	125T15-17010	RIM FRONT WHEEL
HS150T-2	5	44102-145-0000	125T15-34021	FRONT BRAKE DISK

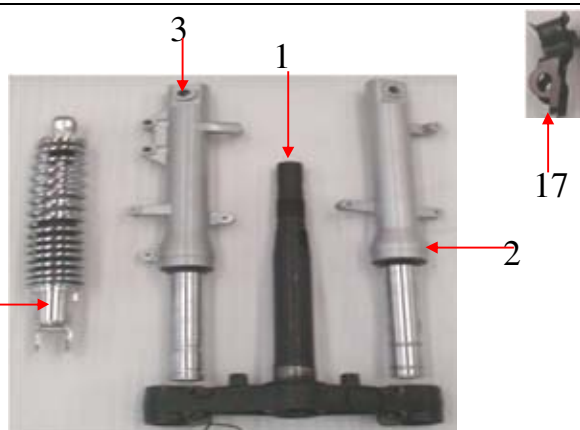

17

2

1

3

4

5

6

7

8

9

10

11

12

14

16

15

13

4

3

1

5

11



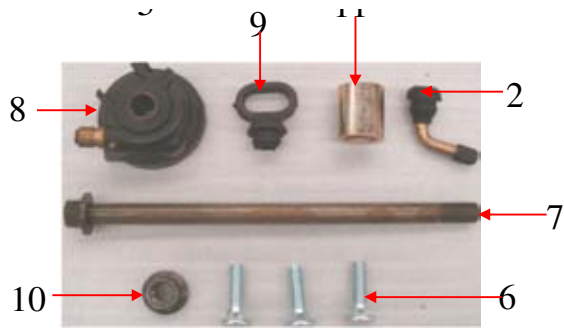

HS150T-2	6	70.1-8-30	125-T0010-005	SEAR SCREW, BRAKE DISK
HS150T-2	7	90206-145-0000	GB/T5787-86	FR. AXLE
HS150T-2	8	36510-145-0000	125T15-20010	COUNTER
HS150T-2	9	36330-145-0000	125T15-27003	THIMBLE
HS150T-2	10	6187-12-00	GB/T6187-2000	NUT M12
HS150T-2	11	90207-145-0000	125-T0010-004	SPACERΦ12.5*Φ20*22

图20 车架总成

(FRAME ASSY)

型号	序号	图号	零部件编码	英文名称
TOTAL NO	NO		PQRT NO	ENGLISH NAME
HS150T-2	1	51101-145D-0000	150T2A-15001 4D	MAIN FRAME
HS150T-2	2	54272-145-0000	125T15-15002	HOLDER HORN
HS150T-2	3	54273-145-0000	125T15-15003	BRACKET, FUEL TANK
HS150T-2	4	54301-145-0000	125T15-15006	CRADLE
HS150T-2	5	85717-145-0000	125T15-15012	CUSHION LOCK BASE
HS150T-2	6	54203-145-0000	125T15-15013	HOLDER L. R. FENDER
HS150T-2	7	54204-145-0000	125T15-15014	HOLDER R. R. FENDER
HS150T-2	8	54271-145-0000	125T15-15015	HOLDER FR. SADDLE
HS150T-2	9	16.06.5787	GB/T5787-86	BOLT M 6*16
HS150T-2	10	12.08.5787	GB/T5787-86	BOLT M 8*12
HS150T-2	11	90206-145-0000	GB/T5787-86	SHAFT CRADLE
HS150T-2	12	5787-10-55	GB/T5787-86	BOLT M 10*55
HS150T-2	13	6187-10-00	GB/T6187-2000	NUT M10
HS150T-2	14	12.06.5787	GB/T5787-86	BOLT M 6*12
HS150T-2	15	16.08.5787	GB/T5787-86	BOLT M8*16
HS150T-2	16	92114-145-0200	125T-T0025	NAMEPLATE

图21 油箱总成

FUEL TANK ASSY

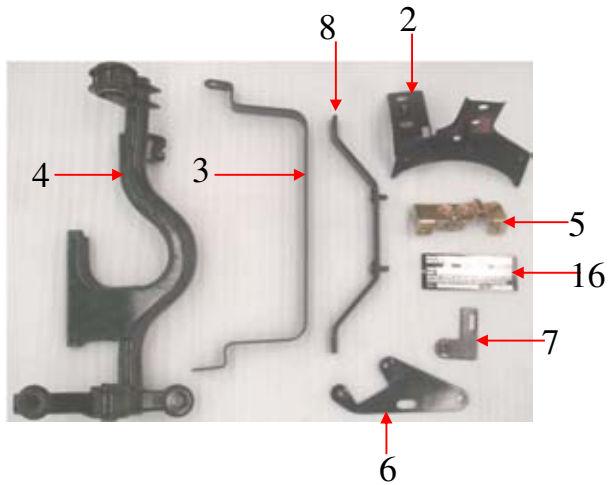
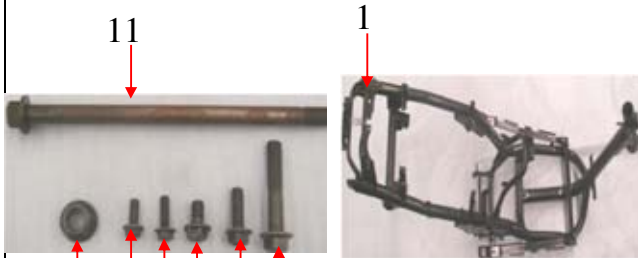

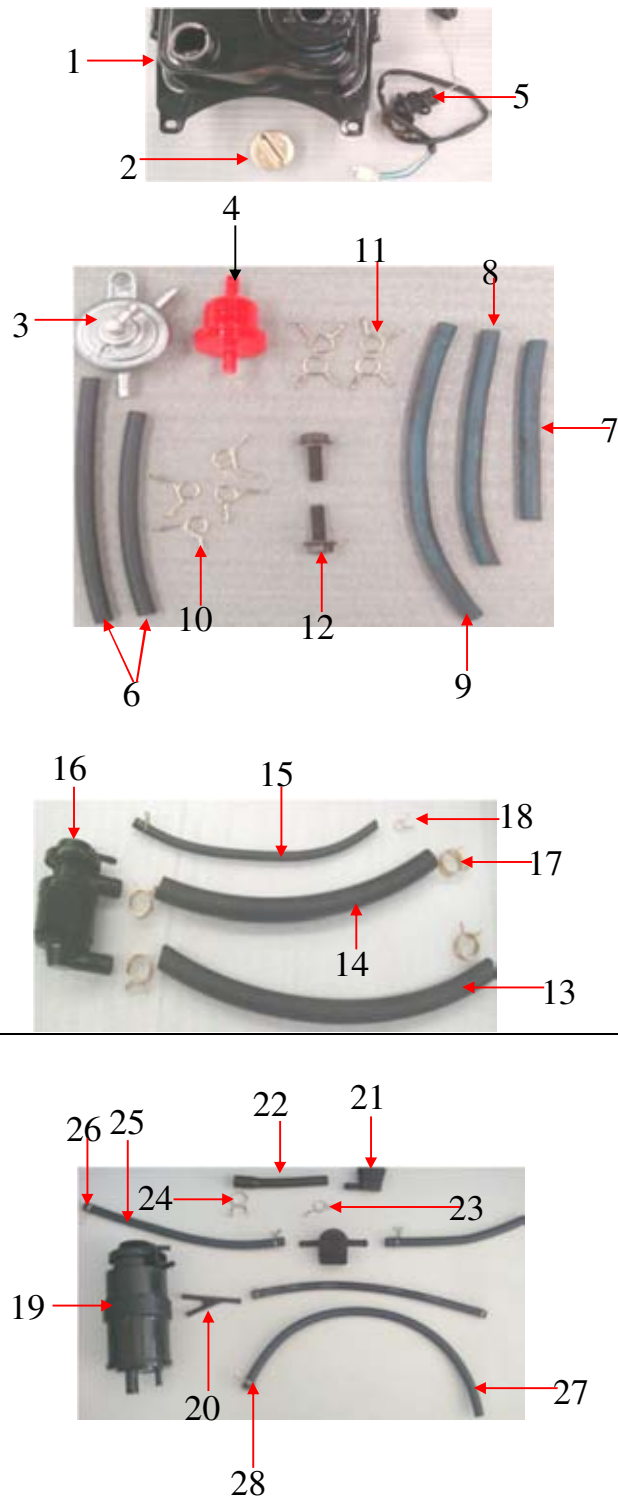

型号	序号	图号	零部件编码	英文名称
TOTAL NO	NO		PQRT NO	ENGLISH NAME
HS150T-2	1	81101-145-0000	125T15-22001	FUEL TANK
HS150T-2	2	81301-145-0000	125T15-22002	CAP COMP FUEL FILLER
HS150T-2	3	81410-145-0000	125T15-22003	FUEL COCK
HS150T-2	4	16610-145-0000	125T-T0032	FILTER
HS150T-2	5	36210-145-0000	125T15-24020	FUEL SENSOR
HS150T-2	6	16507-145-0000	125T-T0011	VACVUM PIPE
HS150T-2	7	16501-145-0000	125T-T0012	TUBE 1
HS150T-2	8	16501-145-0000	125T-T0012	TUBE2
HS150T-2	9	16501-145-0000	125T-T0012	TUBE 3
HS150T-2	10	90401-145-0000	125T-T0013	RING $\Phi 7*1$
HS150T-2	11	90402-145-0000	125T-T0014	RING $\Phi 8*1$
HS150T-2	12	12.06.5787	GB/T5787-86	BOLT M6*12
HS150T-2	13	18502-145-0000	125T-T0015	VENTILATE PIPE
HS150T-2	14	18502-145-0000	125T-T0015	VENTILATE PIPE
HS150T-2	15	16507-145-0000	125T-T0011	VACVUM PIPE
HS150T-2	16	18510-145-0000	125T-T0016	THROTTLE
HS150T-2	17	90403-145-0000	125T-T0017	PIPE HOOP
HS150T-2	18	90401-145-0000	125T-T0013	RING $\Phi 7*1$
HS150T-2	19	18610-145-0000	125T-29014	
HS150T-2	20	18621-145-0000	125T-29017	
HS150T-2	21	18622-145-0000	125T-29019	
HS150T-2	22	18623-145-0000	125T-29015	
HS150T-2	23	18624-145-0000	125T-29016	
HS150T-2	24	18625-145-0000	125T-29018	
HS150T-2	25	16501-145-0000	125T-T0012	
HS150T-2	26	90402-145-0000	125T-T0014	
HS150T-2	27	16507-145-0000	125T-T0011	

HS150T-2	28	90401-145-0000	125T-T0013	
----------	----	----------------	------------	--

图22 座垫、空气滤清器、后尾架总成

FUEL AND AIR FILTER ASSY



型号	序号	图号	零部件编码	英文名称
TOTAL NO	NO		PQRT NO	ENGLISH NAME
HS150T-2	1	85200-145-0200	125T15-33010	MIRROR ASSY
HS150T-2	2	17100-145-0000	125T15-31010	AIR CLEANER ASSY
HS150T-2	3	71100-145-0000	125T15-30010	SADDLE
HS150T-2	4	16.08.5787	GB/T5787-86	BOLTM8*16
HS150T-2	5	85100-145-0000	125T-T0018	KIT SET
HS150T-2	6	72701-145D-0000	150T2A-12013 4D	COVER RR. CARRIER
HS150T-2	7	72711-145-0000	125T15-15016	RR. CARRIER
HS150T-2	8	12.08.5787	GB/T5787-86	BOLT M8*12
HS150T-2	9	12.06.5787	GB/T5787-86	BOLT M6*12

图23 消声器总成

MUFFLER ASSY

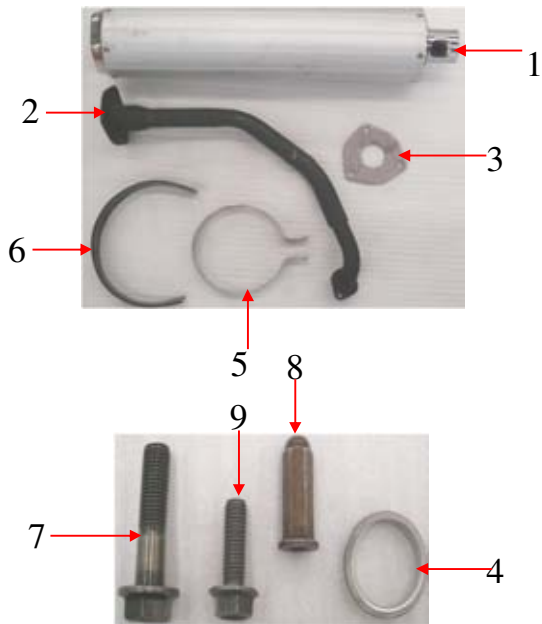

型号	序号	图号	零部件编码	英文名称
TOTAL NO	NO		PQRT NO	ENGLISH NAME
HS150T-2	1	18111-145-0200	125T15-21001	MUFFLER
HS150T-2	2	18115-145-0000	125T15-21002	MUFFLER PIPE
HS150T-2	3	18116-145-0000	125T15-21003	CONNECTING BOARD
HS150T-2	4	18112-145-0000	125T15-21004	GASKET
HS150T-2	5	18113-145-0000	125T15-21005	COLLAR
HS150T-2	6	18114-145-0000	125T15-21006	RUBBER CAP
HS150T-2	7	25.10.5787	GB/T5787-86	BOLT M 10*25
HS150T-2	8	90305-145-0000	125-T0010-002	NUT M6
HS150T-2	9	16.08.5787	GB/T5787-86	BOLT M 8*16



图24 主撑、边撑总成

MAIN&SIDE STAND ASSY

型号	序号	图号	零部件编码	英文名称
TOTAL NO	NO		PQRT NO	ENGLISH NAME
HS150T-2	1	54401-145-0000	125T15-15008	MAIN STAND
HS150T-2	2	91405-145-0000	125T15-29001	SPRING MAIN STAND
HS150T-2	3	25.10.5787	GB/T5787-86	BOLT M10*25
HS150T-2	4	25.06.5787	GB/T5787-86	SCREW M6*25
HS150T-2	5	90209-145-0000	125-T0010-009	BUSH $\phi$ 10.5*15*9
HS150T-2	6	54501-145-0000	125T15-15007	SIDE STAND
HS150T-2	7	90104-145-0000	125-T0010-003	BOLT SIDE STAND M10*22
HS150T-2	8	91403-145-0000	125T15-29002	SPRING SIDE STAND
HS150T-2	9	19871-145-0000	125T-T0026	VENT-PIPE
HS150T-2	10	19872-145-0000	125T-T0027	VENT-PIPE HOOP
HS150T-2	11	54311-145-0000	125T15-27001	CUSHHION WASHER
HS150T-2	12	54402-145-0000	125T15-27002	CUSHION RUBBER

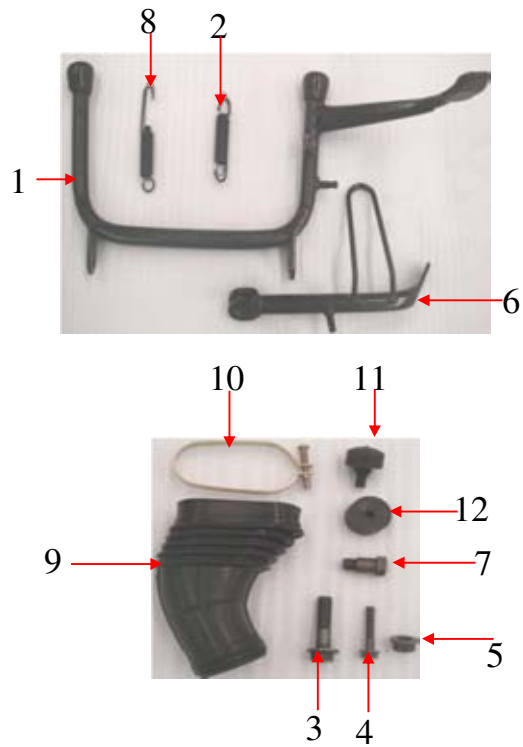

图25 电器总成

ELECTRIC APPLIANCE ASSY

型号	序号	图号	零部件编码	英文名称
TOTAL NO	NO		PQRT NO	ENGLISH NAME
HS150T-2	1	34600-145-0000	125T-T0002	RELAY
HS150T-2	2	33201-145-0000	125T-T0004	C.D.I
HS150T-2	3	32101-145-0000	125T-T0007	RECTIFIER
HS150T-2	4	35200-145D-0200	150T2A-130204D	TAIL LIGHT
HS150T-2	5	34841-145-0200	125T15-14001	REAR REFLECTOR
HS150T-2	6	6170-5-00	GB/T6170	NUT M 5
HS150T-2	7	12.06.5787	GB/T5787-86	BOLT M6*12
HS150T-2	8	35100-145D-0200	150T2A-130104D	HEAD LIGHT
HS150T-2	9	36120-145-0400	125T15-24010	SPEEDOMETER

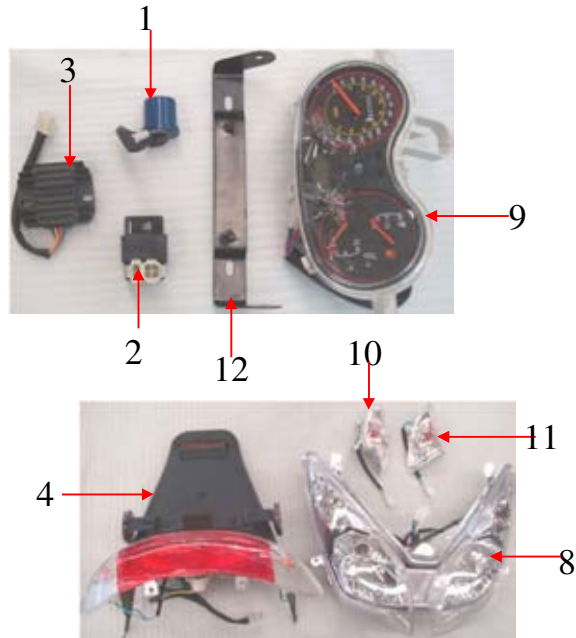
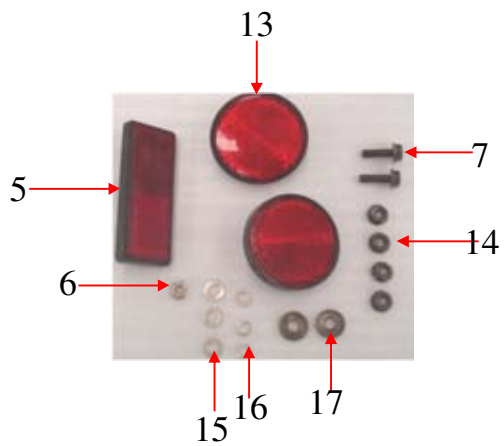

HS150T-2	10	35400-145D-0200	150T2A-130404D	FR. R. TURNNING LIGHT
HS150T-2	11	35300-145D-0200	150T2A-130304D	FR L. TURNNING LIGHT
HS150T-2	12	54211-145D-0100	150T2A-15021	REAR LICENSE BRACKT
HS150T-2	13	34831-145-0200	125T15-14002	SIDE REFLECTOR
HS150T-2	14	6177.1-6-00	GB/T6177.1	NUT M6
HS150T-2	15	96-6-00	GB/T96-85	WASHER 6
HS150T-2	16	96-6-00	GB/T93-87	SPRING WASHER 6
HS150T-2	17	96-6-00	GB/T96-85	WASHER PLAIN Φ6MM

图26 电器总成

ELECTRIC APPLIANCE ASSY

型号	序号	图号	零部件编码	英文名称
TOTAL NO	NO		PQRT NO	ENGLISH NAME
HS150T-2	1	37101-145-0000	125T15-25001	SWITCH , HEAD LIGHT
HS150T-2	2	37102-145-0000	125T15-25002	SWITCH ,STARTER
HS150T-2	3	37103-145-0000	125T15-25003	SWITCH ,DIMMER
HS150T-2	4	37104-145-0000	125T15-25004	SWITCH ,HORN
HS150T-2	5	37105-145-0000	125T15-25005	SWITCH , WINKER
HS150T-2	6	37106-145-0000	125T15-25006	SWITCH ,PISTON LIGHT
HS150T-2	7	37220-145-0000	125T-T0001	SWITCH, FLAMEOUT
HS150T-2	8	34500-145-0400	125T-T0003	HORN
HS150T-2	9	33100-145-0000	125T-T0005	IGNITION COIL COMP
HS150T-2	10	37710-145-0000	125T-T0006	RELAY
HS150T-2	11	32200-145-0000	125T-T0008	BATTARY
HS150T-2	12	34110-145D-0000	125T15-23010	HARDNEES WIRE
HS150T-2	13	34120-145D-0000	125T15-23011	SIDE WIRE
HS150T-2	14	34101-145-0000	125T15-23013	GROUND WIRE .A
HS150T-2	15	34101-145-0000	125T15-23014	GROUND WIRE .B

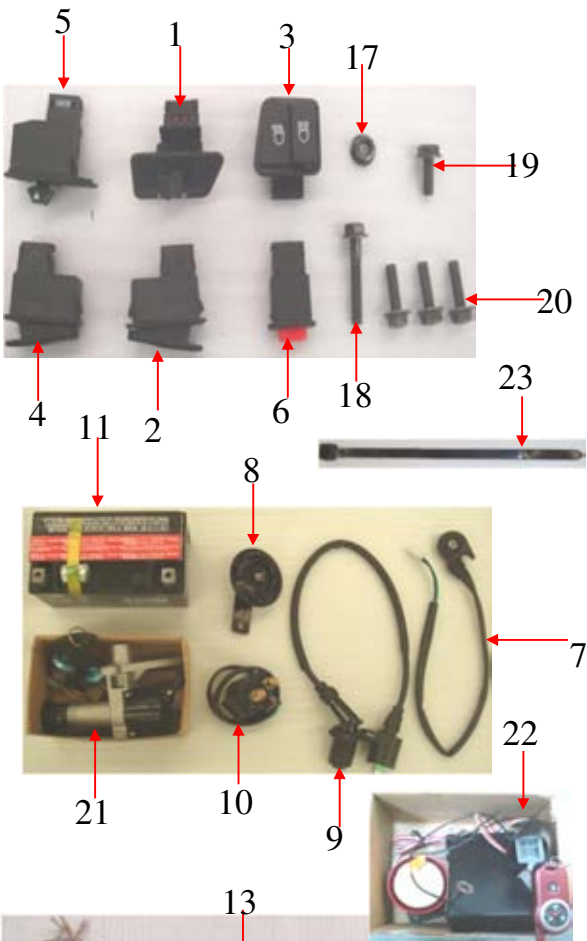

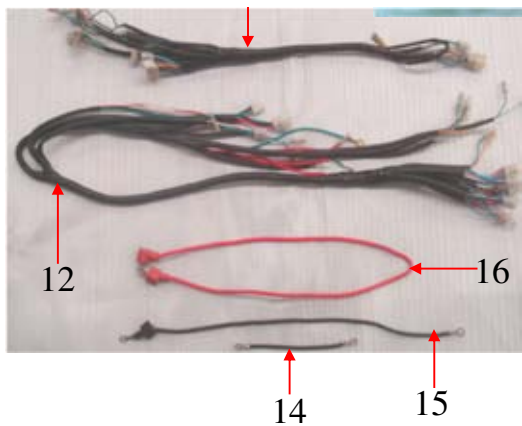

HS150T-2	16	34102-145-0000	125T15-23012	POWER WIRE
HS150T-2	17	6177.1-6-00	GB/T6177.1	NUT M6
HS150T-2	18	30.06.5787	GB/T5787-86	BOLT M6*30
HS150T-2	19	12.06.5787	GB/T5787-86	BOLT M6*12
HS150T-2	20	20.06.5787	GB/T5787-86	BOLT M6*20
HS150T-2	21	85710-145-0000	125T15-26010	ALL LOCKS
HS150T-2	22	34900-145-0000	125T-T0030-001	BURGLERY DEFENDER
HS150T-2	23	91524-145-0000	125T-T0009	

图27 塑料件

PLASTIC PARTS

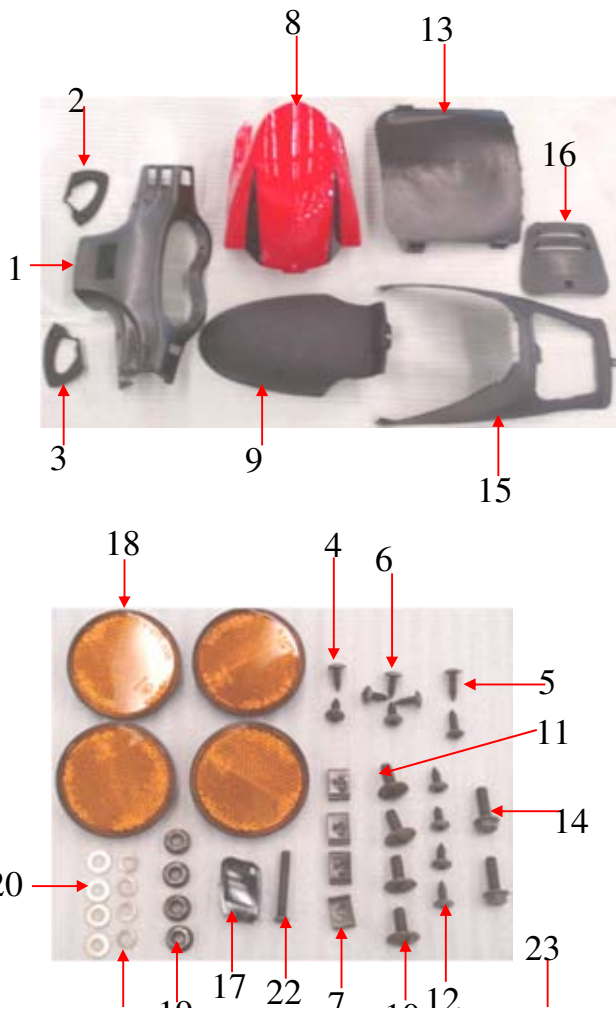

型号	序号	图号	零部件编码	英文名称
TOTAL NO	NO		PQRT NO	ENGLISH NAME
HS150T-2	1	82521-145D-0000	150T2A-12026 4D	RR COVER SPEEDOMETER
HS150T-2	2	82522-145D-0000	150T2A-12022 4D	L. FENDER, SPEEDOMETER CASE
HS150T-2	3	82523-145D-0000	150T2A-12023 4D	R. FENDER, SPEEDOMETER CASE
HS150T-2	4	845-4.2-12	GB/845-85	SCREW TAPPING ST4.2*16
HS150T-2	5	845-4.2-16	GB/845-85	SCREW TAPPING ST4.2*16
HS150T-2	6	845-4.8-12	GB/845-85	SCREW TAPPING ST4.8*12
HS150T-2	7	90316-145-0000	125-T0010-001	CLIP
HS150T-2	8	82171-145D-0000	150T2A-12011 4D	FR. MUOGUARO, FR. WHEEL
HS150T-2	9	82172-145D-0000	150T2A-12012 4D	FR. MUOGUARO, RR. WHEEL
HS150T-2	10	818-6-25	GB/T818-88	BOLT M6*25
HS150T-2	11	818-6-16	GB/T818-88	SCREW M6*16
HS150T-2	12	845-4.2-12	GB/T845-85	SCREW TAPPINGST4.2*12
HS150T-2	13	82802-145D-0000	150T2A-12031 4D	BOTTOM COVER
HS150T-2	14	12.06.5787	GB/T5787-86	BOLTM6*12
HS150T-2	15	82133-145D-0000	150T2A-12036 4D	COVER MIDDLE
HS150T-2	16	82134-145D-0000	150T2A-12037 4D	CENTER COVER
HS150T-2	17	82524-145D-0000	150T2A-12043 4D	METER WATCH COVER
HS150T-2	18	34821-145-0200	125T15-14002	SIDE REFLECTOR
HS150T-2	19	6177.1-6-00	GB/T6177.1	NUT M6
HS150T-2	20	63-6-00	GB/T96-85	WASHER PLAIN Φ6MM



HS150T-2	21	93-6-00	GB/T93-87	
HS150T-2	22	823-5-35	GB/T823-88	SCREW M5*35
HS150T-2	23	90603-145-0000	125T12-27017	

图28 塑料件

PLASTIC PARTS

型号	序号	图号	零部件编码	英文名称
TOTAL NO	NO		PQRT NO	ENGLISH NAME
HS150T-2	1	82301-145D-0000	150T2A-12004 4D	REAR LEFT SIDE PLATE
HS150T-2	2	82401-145D-0000	150T2A-12005 4D	REAR RIGHT SIDE PLATE
HS150T-2	3	82302-145D-0000	150T2A-12025 4D	DECORATION PLATE,REAR RIGHT SIDE PLATE
HS150T-2	4	82402-145D-0000	150T2A-12024 4D	DECORATION PLATE,REAR RIGHT SIDE PLATE
HS150T-2	5	82211-145D-0000	150T2A-12009 4D	REAR CENTER CONNECTING PLATE
HS150T-2	6	83203-145D-0000	150T2A-12008 4D	REAR PROTECTION PIECE
HS150T-2	7	12.06.5787	GB/T5787-86	BOLT M6*12
HS150T-2	8	90501-145-0000	125T15-27008	PLASTIC SCREW
HS150T-2	9	845-4.2-12	GB/T845-85	TAPPING SCREW ST4.2*12
HS150T-2	10	845-4.8-16	GB/T845-85	TAPPING SCREW ST4.8*16
HS150T-2	11	90316-145-0000	125-T0010-001	CLIP
HS150T-2	12	82731-145D-0000	150T2A-12032 4D	PEDAL
HS150T-2	13	83202-145D-0000	150T2A-12006 4D	FRONT RIGHT PROTECTION PIECE
HS150T-2	14	83201-145D-0000	150T2A-12007 4D	FRONT LEFT PROTECTION PIECE
HS150T-2	15	82144-145D-0000	150T2A-12041 4D	HELMET HANG HOOK COMP
HS150T-2	16	90311-145-0000	125-T0010-010	CLIP WITH NUT
HS150T-2	17	823-5-20	GB/T823-88	SCREW M5*20
HS150T-2	18	845-4.2-16	GB/T845-85	TAPPING SCREW ST4.2*16
HS150T-2	19	5787-6-35	GB/T5787-86	BOLT M6*35
HS150T-2	20	16.06.5787	GB/T5787-86	BOLT M6*16
HS150T-2	21	16.06.5787	GB/T5787-86	SCREW M6*16
HS150T-2	22	82131-145D-0000	150T2A-12034 4D	GOODS CASE
HS150T-2	23	82132-145D-0000	150T2A-12035 4D	GOODS CASE BOTTOM COVER
HS150T-2	24	6177.1-6-00	GB/T6177.1-2000	NUT M6
HS150T-2	25	82141-145D-0000	150T2A-12027 4D	FRONT DOCUMENT CASE

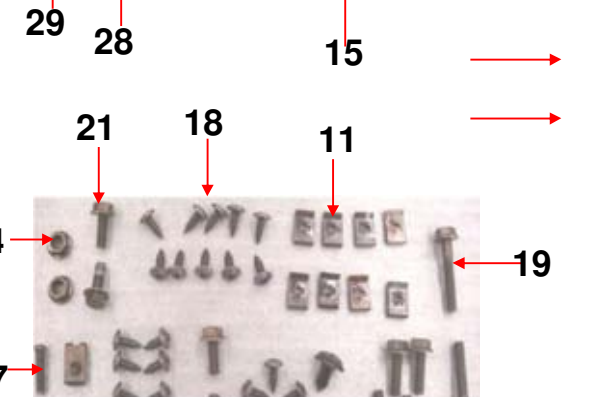



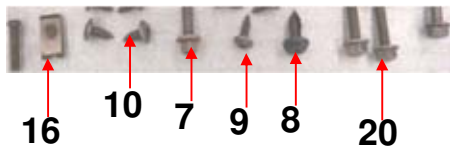

HS150T-2	26	82142-145D-0000	150T2A-12028 4D	FRONT DOCUMENT CASE COVER
HS150T-2	27	82201-145D-0000	150T2A-12042 4D	REAR WHEEL FENDER
HS150T-2	28	82732-145D-0000	150T2A-12033 4D	Battery cover
HS150T-2	29	82143-145D-0000	150T2A-12029 4D	VIN NUMBER COVER

图29 塑料件

FIG28(PLASTIC PARTS)

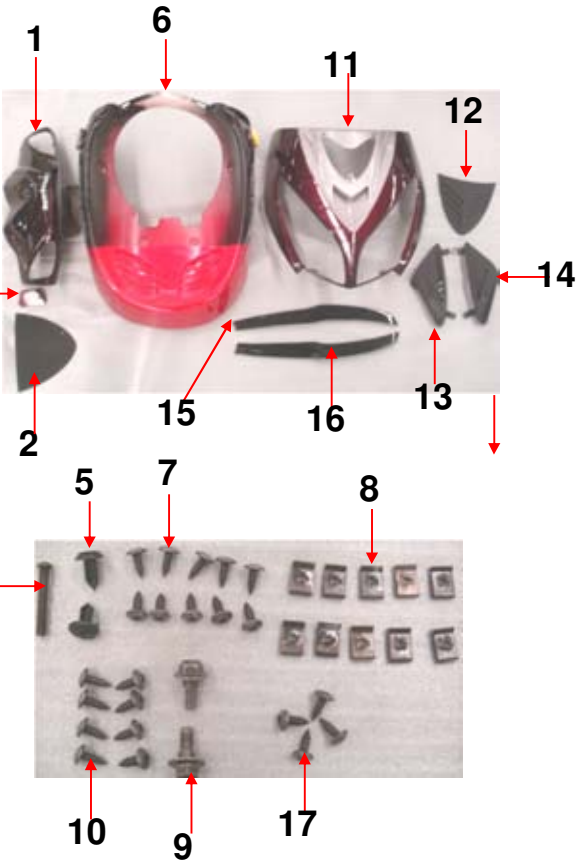

型号	序号	图号	零部件编码	英文名称
TOTAL NO	NO		PQRT NO	ENGLISH NAME
HS150T-2	1	82511-145D-0000	150T2A-12001 4D	HEAD COVER FRONT
HS150T-2	2	82513-145D-0000	150T2A-12019 4D	FRONT DECORATION PLATE
HS150T-2	3	82512-145D-0000	150T2A-12014 4D	DISK BRAKE COVER
HS150T-2	4	823-5-35	GB/T823-88	SCREW M5*35
HS150T-2	5	90501-145-0000	125T15-27008	PLASTIC SCREW
HS150T-2	6	82801-145D-0000	150T2A-12003 4D	FRONT SHROUD
HS150T-2	7	845-4.8-16	GB/T845-85	TAPPING SCREW ST4.8*16
HS150T-2	8	90316-145-0000	125-T0010-001	CLIP
HS150T-2	9	90104-145-0000	125-T0010-003	BOLT M6*18
HS150T-2	10	845-4.2-12	GB/T845-85	TAPPING SCREW ST4.2*12
HS150T-2	11	82111-145D-0000	150T2A-12002 4D	FRONT COVER
HS150T-2	12	82114-145D-0000	150T2A-12021 4D	FRONT DECORATION PIECE
HS150T-2	13	82112-145D-0000	150T2A-12015 4D	FRONT LEFT WINDSHIELD
HS150T-2	14	82113-145D-0000	150T2A-12016 4D	FRONT RIGHT WINDSHIELD
HS150T-2	15	82303-145D-0000	150T2A-12018 4D	REAR LEFT DECORATION PIECE
HS150T-2	16	82403-145D-0000	150T2A-12017 4D	REAR RIGHT DECORATION PIECE
HS150T-2	17	845-4.2-12	GB/T845-85	TAPPING SCREW ST4.2*12

图30 脚踏皮

FOOT PEDAL FUR

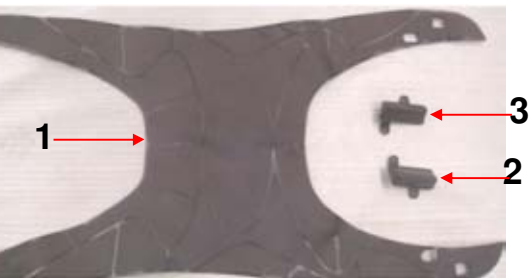

型号	序号	图号	零部件编码	英文名称
TOTAL NO	NO		PQRT NO	ENGLISH NAME
HS150T-2	1	82735-145D-0000	150T2A-27004 4D	FOOT PEDAL FUR
HS150T-2	2	82734-145D-0000	150T2A-12038 4D	RIGHT FOOT PRESSURE PLATE
HS150T-2	3	82733-145D-0000	150T2A-12039 4D	LEFT FOOT PRESSURE PLATE

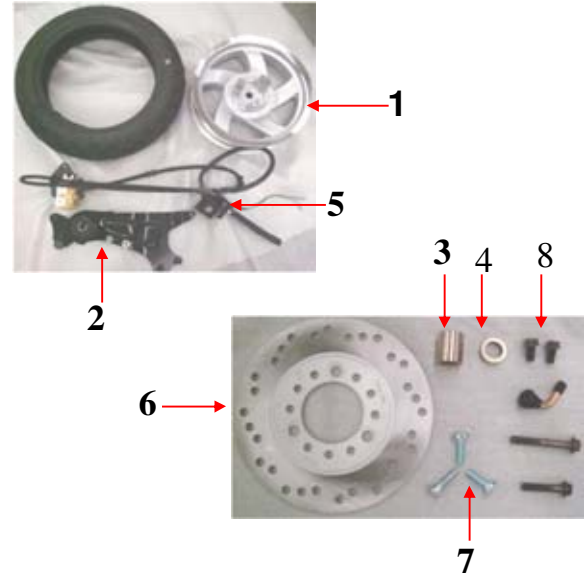

图30 后轮圈、消声器连接板总成

REAR WHEELGASKET

型号	序号	图号	零部件编码	英文名称
TOTAL NO	NO		PQRT NO	ENGLISH NAME
HS150T-2	1	41210-145-0200	125T15-17011	REAR WHEELGASKET
HS150T-2	2	18303-145-0100	125T15-15017G	REAR CONNECTINGPLATE
HS150T-2	3	90207-145-0000	125-T0010-004	SPACERΦ17*Φ25*27
HS150T-2	4	90207-145-0000	125-T0010-004	SPACERΦ17*Φ25*7
HS150T-2	5	44500-145-0200	125T15-34020	REAR LIQUID BRAKE ASSY
HS150T-2	6	44502-145-0000	125T15-34022	REAR BRAKE PLATE
HS150T-2	7	90102-145-0000	125-T0010-005	SETTING SCREW M8×25,REAR BRAKE
HS150T-2	8	10.08.5787	GB/T5787-86	BOLT M8×10
HS150T-2				VR Bremsbelagsatz
HS150T-2				HR Bremsbelagsatz

67 → 9 8 4 1